

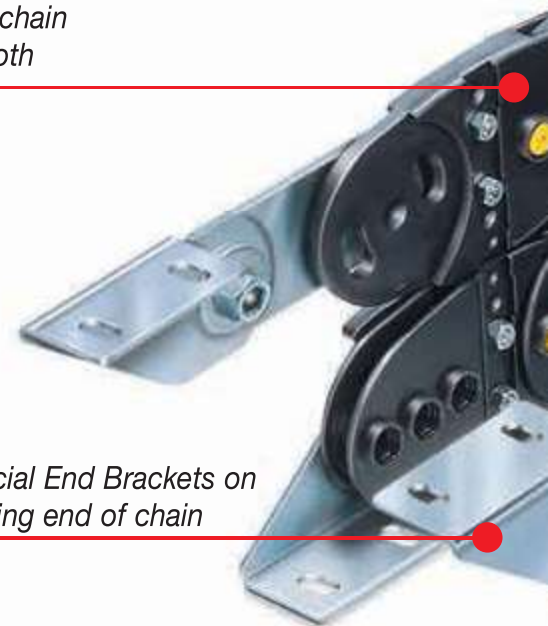

Nylon Cable Chains Sliding Series

326SU Series	page 152
326B Series	page 154
328SU Series	page 156
328B Series	page 158
319ZE Series	page 160
319B Series	page 162
329B Series	page 164
329SU Series	page 166
329CD Series	page 168
478MU Series	page 170
478PU Series	page 172
60PU Series	page 174
80PU Series	page 176
Channel guide for long travel distance	
For 445-660A-770A-326-328 20P-30P-60-H45-H57 Series	page 178
For 478-319-329-80-35P-35PC-40P-H80-H110 Series	page 180
For 326-328-60-H57 Series	page 182

*Inner surface of chain
completely smooth*



*Special End Brackets on
moving end of chain*

Triple connecting Pivot Pin which offers high integrity in high performance applications

Nylon separator. Cables can be laid apart from each other

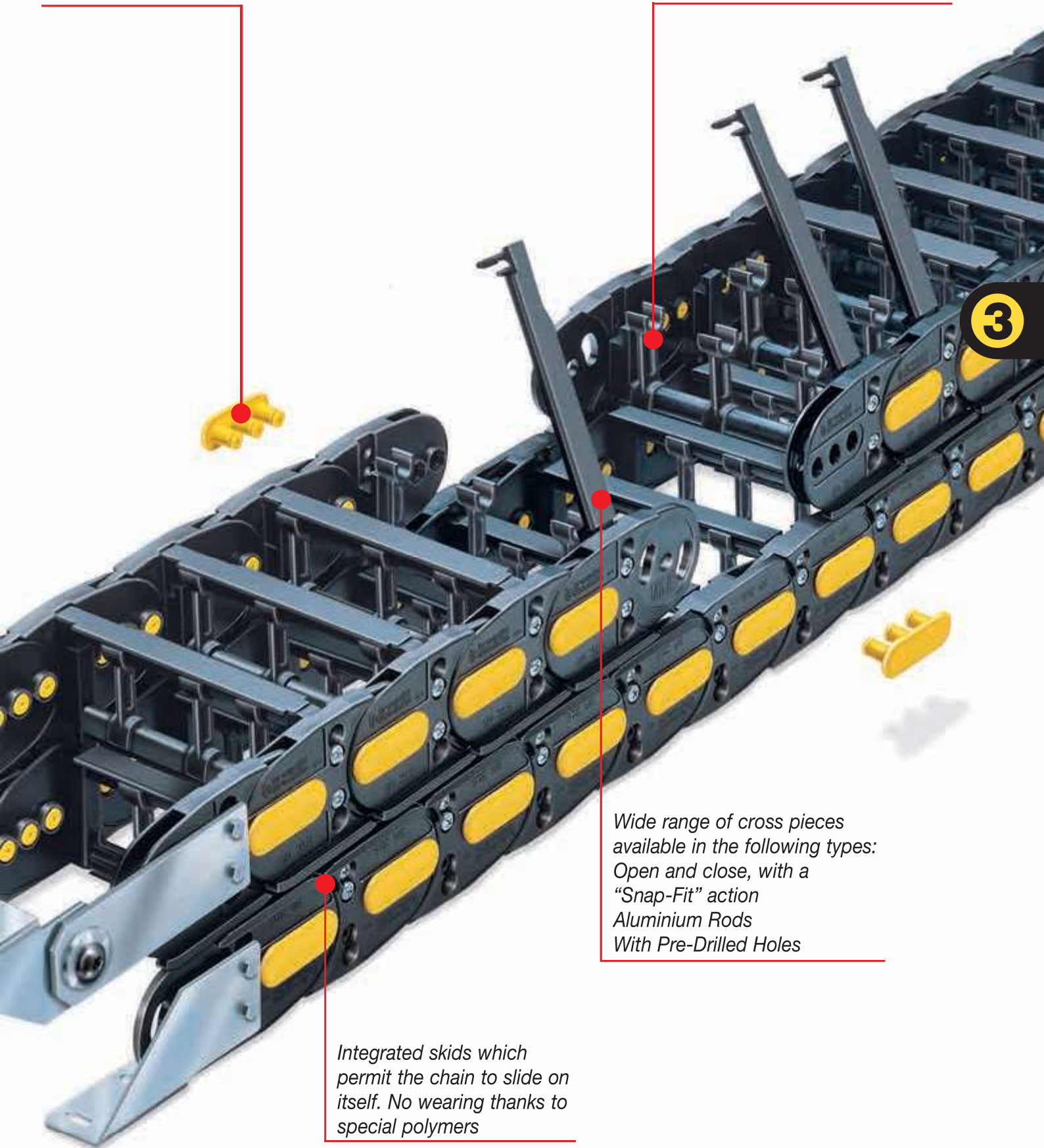

3

*Wide range of cross pieces available in the following types:
Open and close, with a "Snap-Fit" action
Aluminium Rods
With Pre-Drilled Holes*

Integrated skids which permit the chain to slide on itself. No wearing thanks to special polymers

Serie Sliding

326SU

Nylon Sliding Cable Chain with opening frames

Inner height (D) 37 mm

Strong double share Sideband & Frame construction with large anti-friction triple-pin. The chain incorporates large sliding-skid surfaces to offer durability, even with high speed/loads. Frames opening from inner radius and outer radius. As standard the chain comes with frames every second link, on request with frames every link. Modular separator systems are available.

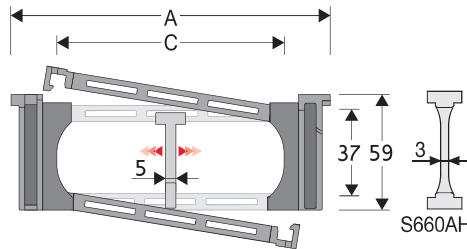

Separator

- Unassembled Part.no S306SM
- Assembled Part.no S306SMMC

Strong-hold separator for C > 200 mm

- Unassembled Part.no S660AH
- Assembled Part.no S660AHMCI for chain opening outer radius
- Assembled Part.no S660AHMCE for chain opening inner radius

Pin Part.no PG307

Technical characteristics

Speed	2 m/s
Acceleration	4 m/s ²

For higher requirements please consult our technical dept.

A	B	C	D	R	Weight/m	Chain
mm	mm	mm	mm	mm	kg	Part Number
106	59	61	37	107-150-200-250-300	1,33	326SU061 □□□ *
117	59	72	37	107-150-200-250-300	1,33	326SU072 □□□ *
131	59	86	37	107-150-200-250-300	1,40	326SU086 □□□ *
137	59	92	37	107-150-200-250-300	1,41	326SU092 □□□ *
141	59	96	37	107-150-200-250-300	1,43	326SU096 □□□ *
151	59	106	37	107-150-200-250-300	1,46	326SU106 □□□ *
156	59	111	37	107-150-200-250-300	1,46	326SU111 □□□ *
163	59	118	37	107-150-200-250-300	1,48	326SU118 □□□ *
173	59	128	37	107-150-200-250-300	1,49	326SU128 □□□ *
181	59	136	37	107-150-200-250-300	1,54	326SU136 □□□ *
192	59	147	37	107-150-200-250-300	1,57	326SU147 □□□ *
206	59	161	37	107-150-200-250-300	1,61	326SU161 □□□ *
231	59	186	37	107-150-200-250-300	1,68	326SU186 □□□ *
256	59	211	37	107-150-200-250-300	1,75	326SU211 □□□ *
267	59	222	37	107-150-200-250-300	1,79	326SU222 □□□ *
281	59	236	37	107-150-200-250-300	1,83	326SU236 □□□ *
308	59	263	37	107-150-200-250-300	1,91	326SU263 □□□ *
317	59	272	37	107-150-200-250-300	1,93	326SU272 □□□ *
342	59	297	37	107-150-200-250-300	2,00	326SU297 □□□ *
368	59	323	37	107-150-200-250-300	2,06	326SU323 □□□ *
390	59	345	37	107-150-200-250-300	2,10	326SU345 □□□ *
418	59	373	37	107-150-200-250-300	2,21	326SU373 □□□ *

*Complete the code by inserting the value of the radius (R): Ex. 326SU118 □ □ □ □
Chain equipped with nylon frame every pitch: complete the code by inserting the letter D.
Ex. 326SU118150 □ □

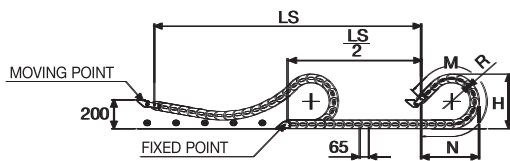

Length of chain (L)
Half travel distance ($\frac{LS}{2}$)
plus length of curve (M)

$$L = \frac{LS}{2} + M$$

R	H	N	M
mm	mm	mm	mm
107	272	280	625
150	358	430	1000
200	458	605	1440
250	558	775	1875
300	658	945	2315



End Brackets

The end brackets set allows the two ends of the chain to be attached to the equipment. One set includes two pivoting end brackets to be installed at the moving point and two standard steel end brackets to be installed at the fixed point.

**Bright Zinc Plated Steel
Movable Type***
(moving point)**

Bright Zinc Plated Steel Type*
(fixed point)**

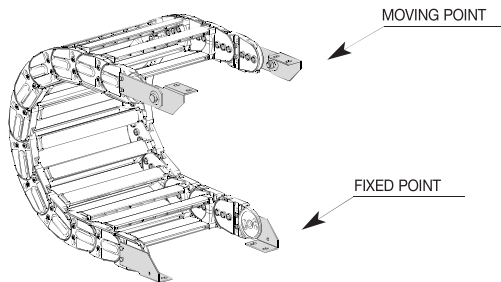
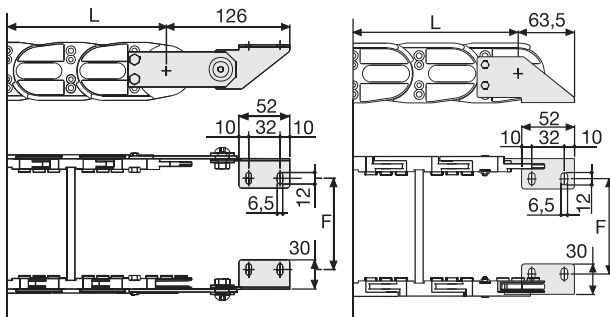

Fig. A
Chain fixed outside the radius. (Fig A)



Chain Type	F mm
326SU061	58
326SU072	69
326SU086	83
326SU092	89
326SU096	93
326SU106	103
326SU111	108
326SU118	115
326SU128	125
326SU136	133
326SU147	144
326SU161	158
326SU186	183
326SU211	208
326SU222	219
326SU236	233
326SU263	260
326SU272	269
326SU297	294
326SU323	320
326SU345	342
326SU373	370

Bright Zinc Plated Steel Type Part Numbers

Complete Set Assembled	
Chain	End Brackets
Type	Set
326SU...	A326KM

Complete Set Unassembled	
Chain	End Brackets
Type	Set
326SU...	A326K

*** Available on request in stainless steel

Serie Sliding

326SU

**Nylon Sliding Cable
Chain with opening
frames**

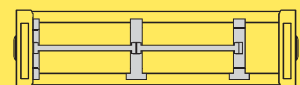

Separation System
To choose the separators see
page. 196

3

How to open the cover.

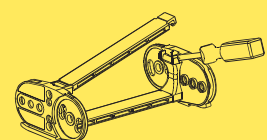
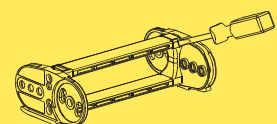

Special tool to remove the
connecting pivots:
Part Number PZ036.



For further information please
consult Brevetti Stendalto's
Technical Office

Serie Sliding

326B

Nylon Sliding Cable Chain with un-screwable aluminium rods

Inner height (D) 30 mm

Strong double share Sideband & Frame construction with large anti-friction triple-pin. The chain incorporates large sliding-skid surfaces to offer durability, even with high speed/loads. The Alu-rod frames are un-screwable from inner and outer radius. As standard the chain comes with frames every second link, on request with frames every link. Separator systems are available.

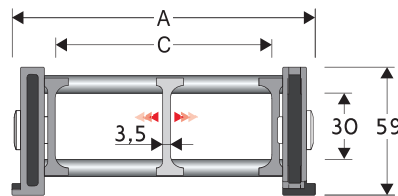

Separator

- Unassembled	Part.no S2000F
- Assembled	Part.no S2000FMC

Pin

Part.no PG307

Technical characteristics

Speed	2 m/s
Acceleration	4 m/s ²

For higher requirements please consult our technical dept.

A	B	C	D	R	Weight/m	Chain
mm	mm	mm	mm	mm	kg	Part Number
115	59	75	30	107-150-200-250-300	1,75	326B075 □□□ *
140	59	100	30	107-150-200-250-300	1,80	326B100 □□□ *
190	59	150	30	107-150-200-250-300	1,90	326B150 □□□ *
240	59	200	30	107-150-200-250-300	2,05	326B200 □□□ *
290	59	250	30	107-150-200-250-300	2,15	326B250 □□□ *
340	59	300	30	107-150-200-250-300	2,25	326B300 □□□ *
C+40	59	30	107-150-200-250-300		326B □□□□□ **

*Complete the code by inserting the value of the radius (R): Ex. 326B100 □□□□

**Complete the code by inserting the value of the quote C and the radius (R): Ex. 326B□□□□□□□□

Chain equipped with aluminium rods every pitch: complete the code by inserting the letter D.

Ex. 326B100150 □

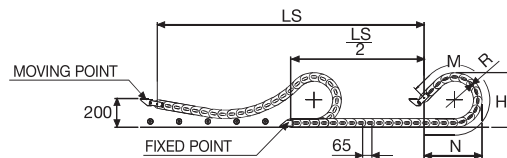

R	H	N	M
mm	mm	mm	mm
107	272	280	625
150	358	430	1000
200	458	605	1440
250	558	775	1875
300	658	945	2315

Length of chain (L)

Half travel distance ($\frac{LS}{2}$)

plus length of curve (M)

$$L = \frac{LS}{2} + M$$



End Brackets

The end brackets set allows the two ends of the chain to be attached to the equipment. One set includes two pivoting end brackets to be installed at the moving point and two standard steel end brackets to be installed at the fixed point.

Bright Zinc Plated Steel Movable Type* (moving point)**

Bright Zinc Plated Steel Type* (fixed point)**

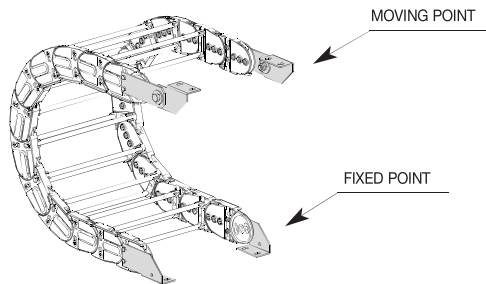
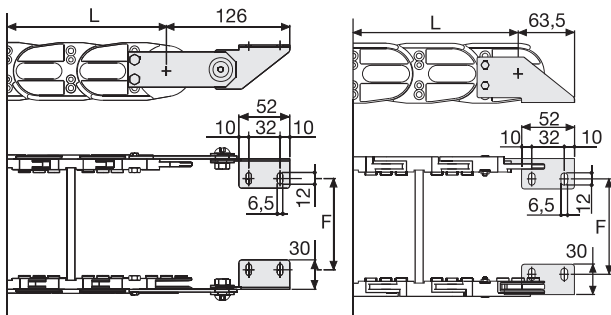

Fig. A
Chain fixed outside the radius. (Fig A)



Chain Type	F mm
326B075	67
326B100	92
326B150	142
326B200	192
326B250	242
326B300	292

Special widths F=A-48

Bright Zinc Plated Steel Type Part Numbers

Complete Set Assembled	
Chain	End Brackets
Type	Set
326B...	A326KM

Complete Set Unassembled	
Chain	End Brackets
Type	Set
326B...	A326K

*** Available on request in stainless steel

Serie Sliding

326B

Nylon Sliding Cable Chain with un-screwable aluminium rods

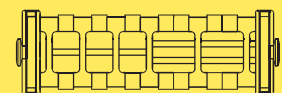

Supplementary movable separators.

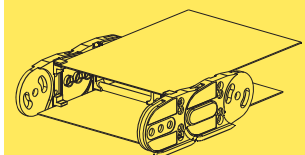

Steel laminar cover.

Special tool to remove the connecting pivots:
Part Number PZ036.



For further information please consult Brevetti Stendalto's Technical Office

Serie Sliding

328SU

Nylon Sliding Cable Chain with opening frames

Inner height (D) 57 mm

Strong double share Sideband & Frame construction with large anti-friction triple-pin. The chain incorporates large sliding-skid surfaces to offer durability, even with high speed/loads. Frames opening from inner radius and outer radius. As standard the chain comes with frames every second link, on request with frames every link. Modular separator systems are available.

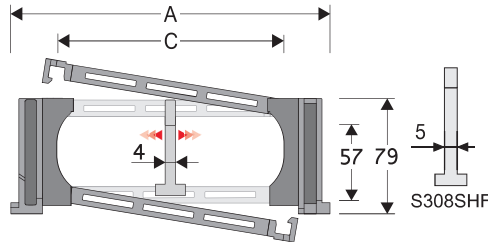

Separator

- Unassembled Part.no S308C
- Assembled Part.no S308CMCI
for chain opening outer radius
- Assembled Part.no S308CMCE
for chain opening inner radius

Strong-hold separator for C > 200 mm

- Unassembled Part.no S308SHF
- Assembled Part.no S308SHFMI
- Assembled Part.no S308SHFMCE

Pin Part.no PG328TP

Technical characteristics

Speed	3,5 m/s
Acceleration	8 m/s ²

For higher requirements please consult our technical dept.

A	B	C	D	R	Weight/m	Chain
mm	mm	mm	mm	mm	kg	Part Number
119	79	61	57	150-180-200-230-280-400	2,70	328SU061 □□□ *
130	79	72	57	150-180-200-230-280-400	2,73	328SU072 □□□ *
144	79	86	57	150-180-200-230-280-400	2,76	328SU086 □□□ *
150	79	92	57	150-180-200-230-280-400	2,78	328SU092 □□□ *
154	79	96	57	150-180-200-230-280-400	2,80	328SU096 □□□ *
164	79	106	57	150-180-200-230-280-400	2,82	328SU106 □□□ *
169	79	111	57	150-180-200-230-280-400	2,82	328SU111 □□□ *
176	79	118	57	150-180-200-230-280-400	2,82	328SU118 □□□ *
186	79	128	57	150-180-200-230-280-400	2,86	328SU128 □□□ *
194	79	136	57	150-180-200-230-280-400	2,89	328SU136 □□□ *
205	79	147	57	150-180-200-230-280-400	2,89	328SU147 □□□ *
219	79	161	57	150-180-200-230-280-400	2,94	328SU161 □□□ *
244	79	186	57	150-180-200-230-280-400	3,01	328SU186 □□□ *
269	79	211	57	150-180-200-230-280-400	3,06	328SU211 □□□ *
280	79	222	57	150-180-200-230-280-400	3,08	328SU222 □□□ *
294	79	236	57	150-180-200-230-280-400	3,14	328SU236 □□□ *
321	79	263	57	150-180-200-230-280-400	3,20	328SU263 □□□ *
330	79	272	57	150-180-200-230-280-400	3,20	328SU272 □□□ *
355	79	297	57	150-180-200-230-280-400	3,29	328SU297 □□□ *
381	79	323	57	150-180-200-230-280-400	3,31	328SU323 □□□ *
403	79	345	57	150-180-200-230-280-400	3,36	328SU345 □□□ *
431	79	373	57	150-180-200-230-280-400	3,49	328SU373 □□□ *

*Complete the code by inserting the value of the radius (R): Ex. 328SU118 □ □ □ □
Chain equipped with nylon frame every pitch: complete the code by inserting the letter D.
Ex. 328SU118150 □ □

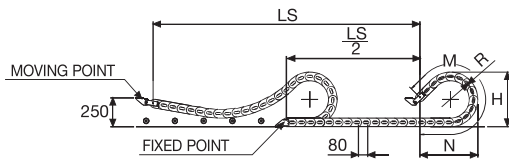

Length of chain (L)

Half travel distance ($\frac{LS}{2}$)

plus length of curve (M)

$$L = \frac{LS}{2} + M$$

R	H	N	M
mm	mm	mm	mm
150	379	425	955
180	439	530	1220
200	479	600	1395
230	539	700	1655
280	639	875	2095
400	879	1285	3145



End Brackets

The end brackets set allows the two ends of the chain to be attached to the equipment. One set includes two pivoting end brackets to be installed at the moving point and two standard steel end brackets to be installed at the fixed point.

Bright Zinc Plated Steel Movable Type*** (moving point)

Bright Zinc Plated Steel Type*** (fixed point)

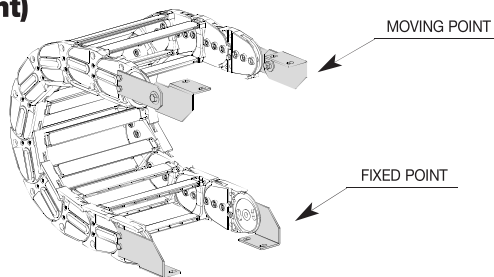
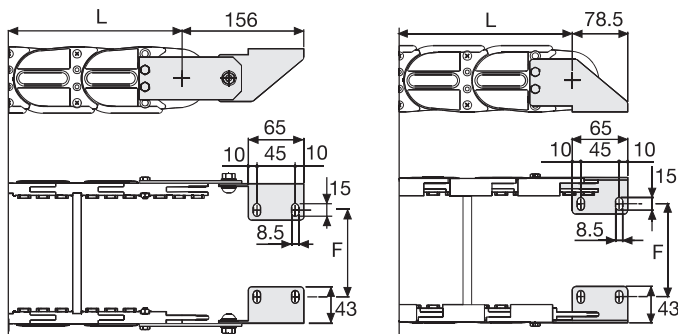

Fig. A
Chain fixed outside the radius. (Fig A)



Chain Type	F mm
328SU061	44
328SU072	55
328SU086	69
328SU092	75
328SU096	79
328SU106	89
328SU111	94
328SU118	101
328SU128	111
328SU136	119
328SU147	130
328SU161	144
328SU186	169
328SU211	194
328SU222	205
328SU236	219
328SU263	246
328SU272	255
328SU297	280
328SU323	306
328SU345	328
328SU373	356

Bright Zinc Plated Steel Type Part Numbers

Complete Set Assembled	
Chain	End Brackets
Type	Set
328SU...	A328KM

Complete Set Unassembled	
Chain	End Brackets
Type	Set
328SU...	A328K

*** Available on request in stainless steel

Serie Sliding

328SU

Nylon Sliding Cable Chain with opening frames

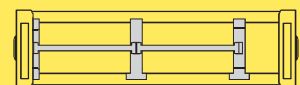

Separation System
To choose the separators see page. 196

3

How to open the cover.

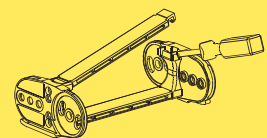
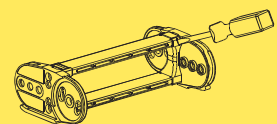

Special tool to remove the connecting pivots:
Part Number PZ038.



For further information please consult Brevetti Stendalto's Technical Office

Serie Sliding

328B

Nylon Sliding Cable Chain with un-screwable aluminium rods

Inner height (D) 48 mm

Strong double share Sideband & Frame construction with large anti-friction triple-pin. The chain incorporates large sliding-skid surfaces to offer durability, even with high speed/loads. The Alu-rod frames are un-screwable from inner and outer radius. As standard the chain comes with frames every second link, on request with frames every link. Separator systems are available.

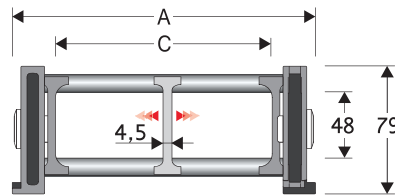

Separator

- Unassembled	Part.no S3000F
- Assembled	Part.no S3000FMC

Pin

Part.no PG328TP

Technical characteristics

Speed	3,5 m/s
Acceleration	8 m/s ²

For higher requirements please consult our technical dept.

A	B	C	D	R	Weight/m	Chain
mm	mm	mm	mm	mm	kg	Part Number
162	79	100	48	150-180-200-230-280-400	2,50	328B100 □□□ *
212	79	150	48	150-180-200-230-280-400	2,60	328B150 □□□ *
262	79	200	48	150-180-200-230-280-400	2,75	328B200 □□□ *
312	79	250	48	150-180-200-230-280-400	2,90	328B250 □□□ *
362	79	300	48	150-180-200-230-280-400	3,00	328B300 □□□ *
C+62	79	48	150-180-200-230-280-400		328B □□□□□ **

*Complete the code by inserting the value of the radius (R): Ex. 328B100 □□□ □

**Complete the code by inserting the value of the quote C and the radius (R): Ex. 328B □□□ □□□ □□

Chain equipped with aluminium rods every pitch: complete the code by inserting the letter D. Ex. 328B100150 □

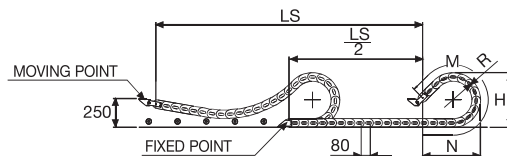

Length of chain (L)

Half travel distance ($\frac{LS}{2}$)

plus length of curve (M)

$$L = \frac{LS}{2} + M$$

R	H	N	M
mm	mm	mm	mm
150	379	425	955
180	439	530	1220
200	479	600	1395
230	539	700	1655
280	639	875	2095
400	879	1285	3145



End Brackets

The end brackets set allows the two ends of the chain to be attached to the equipment. One set includes two pivoting end brackets to be installed at the moving point and two standard steel end brackets to be installed at the fixed point.

Bright Zinc Plated Steel Movable Type*
(moving point)**

Bright Zinc Plated Steel Type*
(fixed point)**

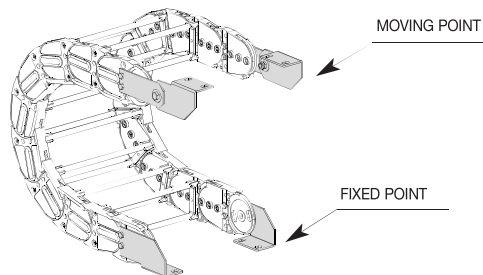
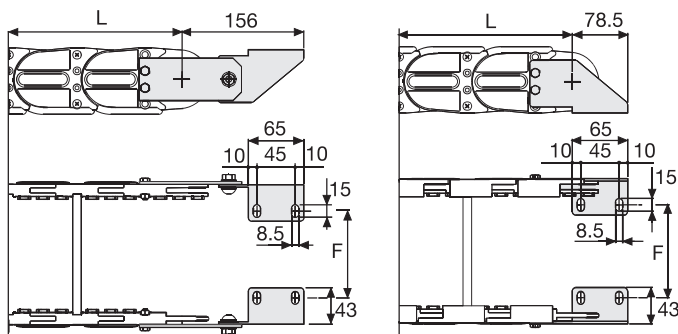

Fig. A
Chain fixed outside the radius. (Fig A)



Chain Type	F mm
328B100	87
328B150	137
328B200	187
328B250	237
328B300	287

Special widths F=A-75

Bright Zinc Plated Steel Type Part Numbers

Complete Set Assembled	
Chain	End Brackets
Type	Set
328B...	A328KM

Complete Set Unassembled	
Chain	End Brackets
Type	Set
328B...	A328K

*** Available on request in stainless steel

Serie Sliding

328B

Nylon Sliding Cable Chain with un-screwable aluminium rods

3

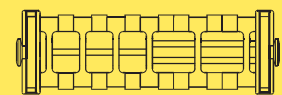

Supplementary movable separators.

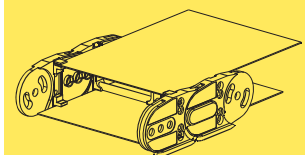

Steel laminar cover.

Special tool to remove the connecting pivots:
Part Number PZ038.



For further information please consult Brevetti Stendalto's Technical Office

Serie Sliding

319ZE

Nylon Sliding Cable Chain with opening frames

Inner height (D) 75,5 mm

Strong double share Sideband & Frame construction with large anti-friction triple pin. The chain features screwed-on interchangeable sliding skids to offer durability even with high speed and loads. Frames open from outer radius.

As standard the chain comes with frames every second link, on request with frames every link. Modular separation systems are available.

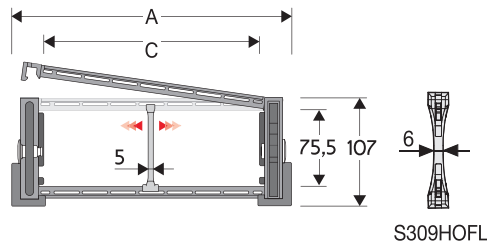

Separator

- Unassembled Part.no S309S/3178
- Assembled Part.no S309/3178SMC

Strong-hold separator

for C > 250 mm

- Unassembled Part.no S309HOFL
- Assembled Part.no S309HOFLMC

Pin

Part.no PG329

Sliding skid

Part.no PAT329

Technical characteristics

Speed	4 m/s
Acceleration	13 m/s ²

For higher requirements please consult our technical dept.

A	B	C	D	R	Weight/m	Chain
mm	mm	mm	mm	mm	kg	Part Number
148	107	84	75,5	200-250-300-350-400-500	4,53	319ZE084 □□□ *
173	107	109	75,5	200-250-300-350-400-500	4,61	319ZE109 □□□ *
180	107	116	75,5	200-250-300-350-400-500	4,64	319ZE116 □□□ *
203	107	139	75,5	200-250-300-350-400-500	4,71	319ZE139 □□□ *
243	107	179	75,5	200-250-300-350-400-500	4,84	319ZE179 □□□ *
278	107	214	75,5	200-250-300-350-400-500	4,95	319ZE214 □□□ *
304	107	240	75,5	200-250-300-350-400-500	5,04	319ZE240 □□□ *
328	107	264	75,5	200-250-300-350-400-500	5,11	319ZE264 □□□ *
354	107	290	75,5	200-250-300-350-400-500	5,19	319ZE290 □□□ *
378	107	314	75,5	200-250-300-350-400-500	5,27	319ZE314 □□□ *
404	107	340	75,5	200-250-300-350-400-500	5,34	319ZE340 □□□ *
428	107	364	75,5	200-250-300-350-400-500	5,43	319ZE364 □□□ *
483	107	419	75,5	200-250-300-350-400-500	5,64	319ZE419 □□□ *
552	107	488	75,5	200-250-300-350-400-500	5,85	319ZE488 □□□ *

*Complete the code by inserting the value of the radius (R): Ex. 319ZE116 □ □ □ □

Chain equipped with nylon frame every pitch: complete the code by inserting the letter D. Ex. 319ZE116250 □ □

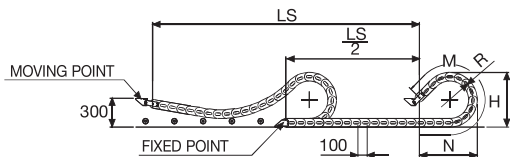

Length of chain (L)

Half travel distance ($\frac{LS}{2}$)

plus length of curve (M)

$$L = \frac{LS}{2} + M$$

R	H	N	M
mm	mm	mm	mm
200	506	595	1345
250	606	765	1780
300	706	940	2220
350	806	1110	2655
400	906	1280	3095
500	1106	1625	3970



End Brackets

The end brackets set allows the two ends of the chain to be attached to the equipment. One set includes two pivoting end brackets to be installed at the moving point and two standard steel end brackets to be installed at the fixed point.

**Bright Zinc Plated Steel
Movable Type***
(moving point)**

**Bright Zinc Plated Steel
Type***
(fixed point)**

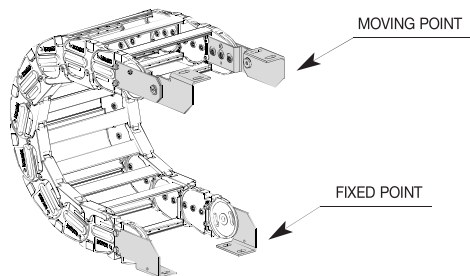
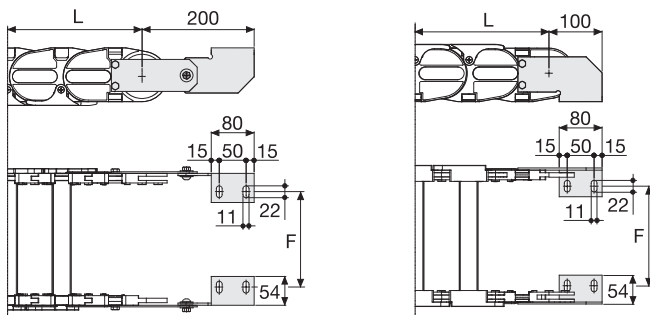

Fig. A
Chain fixed outside the radius. (Fig A)



Chain Type	F mm
319ZE064	40
319ZE084	60
319ZE109	85
319ZE116	92
319ZE139	115
319ZE179	155
319ZE214	190
319ZE240	216
319ZE264	240
319ZE290	266
319ZE314	290
319ZE340	316
319ZE364	340
319ZE419	395
319ZE488	464

Bright Zinc Plated Steel Type Part Numbers

Complete Set Assembled	
Chain	End Brackets
Type	Set
319ZE...	A319KM

Complete Set Unassembled	
Chain	End Brackets
Type	Set
319ZE...	A319K

*** Available on request in stainless steel

Serie Sliding

319ZE

**Nylon Sliding Cable
Chain
with opening frames**

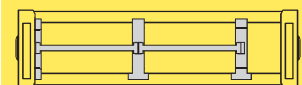

Separation System
To choose the separators see
page. 196

3

How to open the cover.

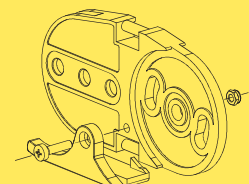
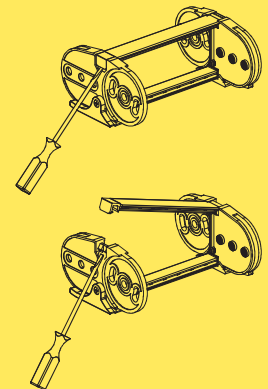

Sliding skid

For further information please
consult Brevetti Stendalto's
Technical Office

End Brackets

The end brackets set allows the two ends of the chain to be attached to the equipment. One set includes two pivoting end brackets to be installed at the moving point and two standard steel end brackets to be installed at the fixed point.

Bright Zinc Plated Steel Movable Type* (moving point)**

Bright Zinc Plated Steel Type* (fixed point)**

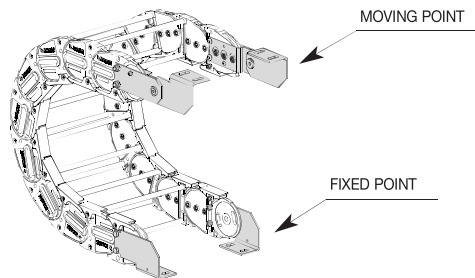
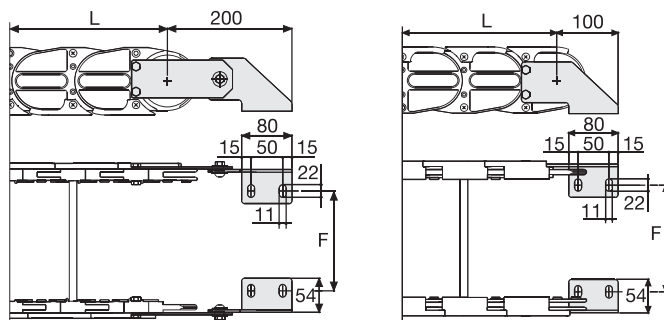

Fig. A
Chain fixed outside the radius. (Fig A)



Chain Type	F mm
319B100	76
319B150	126
319B200	176
319B250	226
319B300	276
319B400	376

Special widths F=A-88

Bright Zinc Plated Steel Type Part Numbers

Complete Set Assembled	
Chain Type	End Brackets Set
319B...	A319KM

Complete Set Unassembled	
Chain Type	End Brackets Set
319B...	A319K

*** Available on request in stainless steel

Serie Sliding

319B

Nylon Sliding Cable Chain with un-screwable aluminium rods

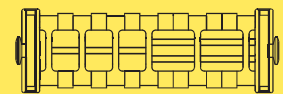

Supplementary movable separators.

3

Version with aluminium draw plates



On request available with aluminium draw plates

Example Part Number:
319T □□□* □□□**

* Inner width (C)
** Bending radius (R)

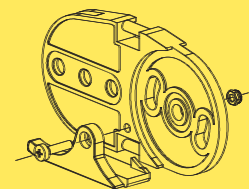

Sliding skid

For further information please consult Brevetti Stendalto's Technical Office

Serie Sliding

329B

Nylon Sliding Cable Chain with un-screwable aluminium rods

Inner height (D) 70 mm

Strong double share Sideband & Frame construction with large anti-friction triple-pin. The chain incorporates large sliding-skid surfaces to offer durability, even with high speed/loads. The Alu-rod frames are un-screwable from inner and outer radius. As standard the chain comes with frames every second link, on request with frames every link. Separator systems are available.

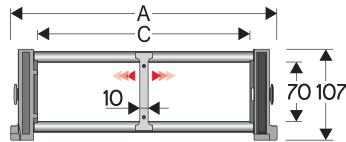

Separator

- Unassembled	Part.no S309C
- Assembled	Part.no S309CMC

Pin

Part.no PG329

Technical characteristics

Speed	3 m/s
Acceleration	13 m/s ²

For higher requirements please consult our technical dept.

A	B	C	D	R	Weight/m	Chain
mm	mm	mm	mm	mm	kg	Part.no
164	107	100	70	150-200-250-300-350-400-500-600	4,25	329B100□□□*
214	107	150	70	150-200-250-300-350-400-500-600	4,45	329B150□□□*
264	107	200	70	150-200-250-300-350-400-500-600	4,60	329B200□□□*
314	107	250	70	150-200-250-300-350-400-500-600	4,75	329B250□□□*
364	107	300	70	150-200-250-300-350-400-500-600	4,90	329B300□□□*
464	107	400	70	150-200-250-300-350-400-500-600	5,25	329B400□□□*
C+64	107	70	150-200-250-300-350-400-500-600		329B□□□□**

*Complete the code by inserting the value of the radius (R): Ex. 329B150□□□□

**Complete the code by inserting the value of the quote C and the radius (R): Ex. 329B□□□□□□□□

Chain equipped with aluminium rods every pitch: complete the code by inserting the letter D. Ex. 329B150200□□

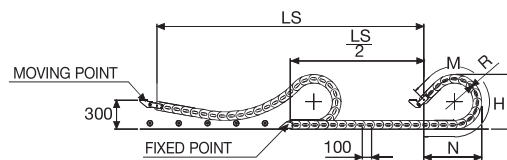

Length of chain (L)
 Half travel distance ($\frac{LS}{2}$)
 plus length of curve (M)

$$L = \frac{LS}{2} + M$$

R	H	N	M
mm	mm	mm	mm
150	406	415	905
200	506	595	1345
250	606	765	1780
300	706	940	2220
350	806	1110	2655
400	906	1280	3095
500	1106	1625	3970
600	1306	1965	4845



Serie Sliding

329B

Nylon Sliding Cable Chain with un-screwable aluminium rods

End Brackets

The end brackets set allows the two ends of the chain to be attached to the equipment. One set includes two pivoting end brackets to be installed at the moving point and two standard steel end brackets to be installed at the fixed point.

Bright Zinc Plated Steel Movable Type* (moving point)**

Bright Zinc Plated Steel Type* (fixed point)**

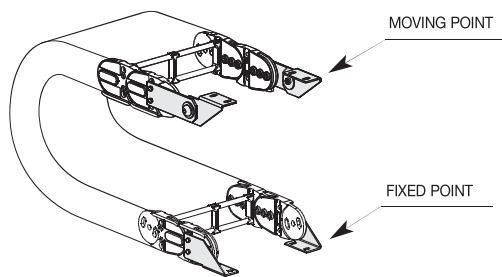
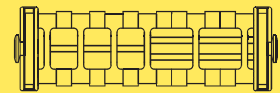
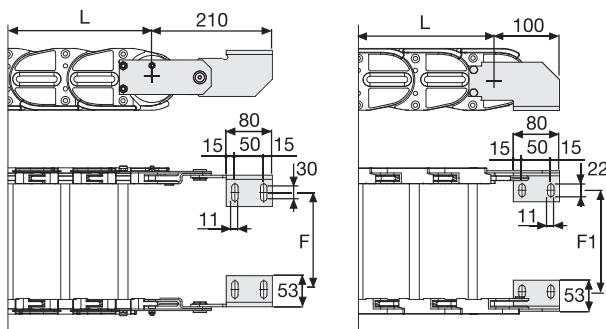

Fig. A
Chain fixed outside the radius. (Fig A)



Supplementary movable separators.

Chain Type	F mm
329B100	76
329B150	126
329B200	176
329B250	226
329B300	276
329B400	376

Special widths F=A-88

Chain Type	F1 mm
329B100	87
329B150	137
329B200	187
329B250	237
329B300	287
329B400	387

Special widths F=A-77

Bright Zinc Plated Steel Type Part Numbers

Complete Set Assembled	
Chain Type	End Brackets Set
329B...	A329BKM

Complete Set Unassembled	
Chain Type	End Brackets Set
329B...	A329BK

*** Available on request in stainless steel

For further information please consult Brevetti Stendalto's Technical Office

Serie Sliding

329SU Nylon Sliding Cable Chain with opening frames

Inner height (D) 75,5 mm

Strong double share Sideband & Frame construction with large anti-friction triple-pin. The chain incorporates large sliding-skid surfaces to offer durability, even with high speed/loads. Frames are opening from inner radius or outer radius. Vertical separators are available

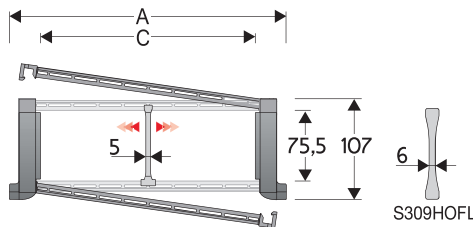

Separator

- Unassembled	Part.no S309S/3178
- Assembled*	Part.no S309S/3178MCI
- Assembled**	Part.no S309S/3178MCE

Strong-hold separator

for C > 250 mm

- Unassembled	Part.no S309HOFL
- Assembled*	Part.no S309HOFLMC

Pin

Part.no PG329

* for chain opening outer radius

** for chain opening inner radius

Technical characteristics

Speed	3 m/s
Acceleration	13 m/s ²

For higher requirements please consult our technical dept.

A	B	C	D	R	Weight/m	Chain
mm	mm	mm	mm	mm	kg	Part Number
148	107	84	75,5	150-200-250-300-350-400-500-600	4,25	329SU084 □□□ *
173	107	109	75,5	150-200-250-300-350-400-500-600	4,33	329SU109 □□□ *
180	107	116	75,5	150-200-250-300-350-400-500-600	4,36	329SU116 □□□ *
203	107	139	75,5	150-200-250-300-350-400-500-600	4,43	329SU139 □□□ *
243	107	179	75,5	150-200-250-300-350-400-500-600	4,56	329SU179 □□□ *
278	107	214	75,5	150-200-250-300-350-400-500-600	4,67	329SU214 □□□ *
304	107	240	75,5	150-200-250-300-350-400-500-600	4,76	329SU240 □□□ *
328	107	264	75,5	150-200-250-300-350-400-500-600	4,83	329SU264 □□□ *
354	107	290	75,5	150-200-250-300-350-400-500-600	4,91	329SU290 □□□ *
378	107	314	75,5	150-200-250-300-350-400-500-600	4,99	329SU314 □□□ *
404	107	340	75,5	150-200-250-300-350-400-500-600	5,06	329SU340 □□□ *
428	107	364	75,5	150-200-250-300-350-400-500-600	5,15	329SU364 □□□ *
483	107	419	75,5	150-200-250-300-350-400-500-600	5,36	329SU419 □□□ *
552	107	488	75,5	150-200-250-300-350-400-500-600	5,57	329SU488 □□□ *

*Complete the code by inserting the value of the radius (R): Ex. 329SU116 □ □ □ □

Chain equipped with nylon frame every pitch: complete the code by inserting the letter D.
Ex. 329SU116250 □

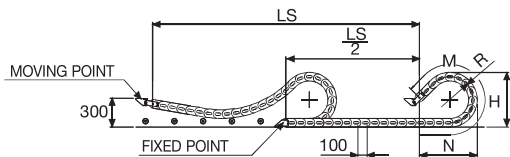

Length of chain (L)

Half travel distance ($\frac{LS}{2}$)

plus length of curve (M)

$$L = \frac{LS}{2} + M$$

R	H	N	M
mm	mm	mm	mm
150	406	415	905
200	506	595	1345
250	606	765	1780
300	706	940	2220
350	806	1110	2655
400	906	1280	3095
500	1106	1625	3970
600	1306	1965	4845



End Brackets

The end brackets set allows the two ends of the chain to be attached to the equipment. One set includes two pivoting end brackets to be installed at the moving point and two standard steel end brackets to be installed at the fixed point.

**Bright Zinc Plated Steel
Movable Type***
(moving point)**

**Bright Zinc Plated Steel
Type***
(fixed point)**

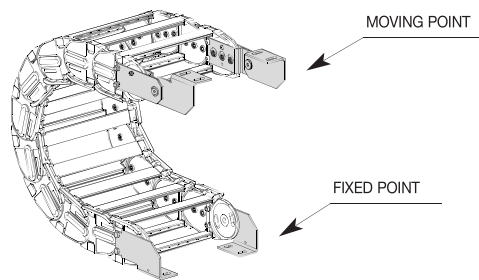
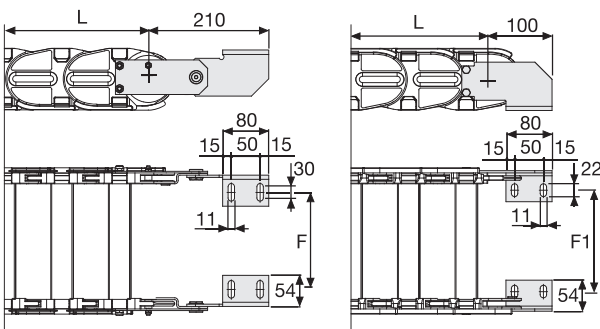

Fig. A
Chain fixed outside the radius. (Fig A)



Chain Type	F mm
329SU084	60
329SU109	85
329SU116	92
329SU139	115
329SU179	155
329SU214	190
329SU240	216
329SU264	240
329SU290	266
329SU314	290
329SU340	316
329SU364	340
329SU419	395
329SU488	464

Chain Type	F1 mm
329SU084	71
329SU109	96
329SU116	103
329SU139	126
329SU179	166
329SU214	201
329SU240	227
329SU264	251
329SU290	277
329SU314	301
329SU340	327
329SU364	351
329SU419	406
329SU488	475

Bright Zinc Plated Steel Type Part Numbers

Chain Type	End Brackets Set
329SU..	A329SU□□□*KM

Chain Type	End Brackets Set
329SU..	A329SU□□□*K

* Inner width (C)

*** Available on request in stainless steel

Serie Sliding

329SU

Nylon Sliding Cable
Chain with opening
frames

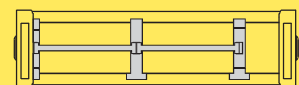

Separation System
To choose the separators see
page. 196

How to open the cover

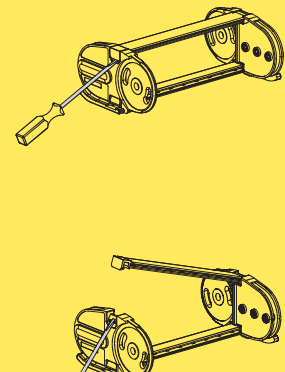

3

For further information please
consult Brevetti Stendalto's
Technical Office

Serie Sliding

329CD

Nylon Sliding Cable Chain with opening aluminium covers

Inner height (D) 75,5 mm

Strong double share Sideband & Frame construction with large anti-friction triple-pin. The chain incorporates large sliding-skid surfaces to offer durability, even with high speed/loads. Aluminium covers are opening from inner radius or outer radius.

Vertical separators are available

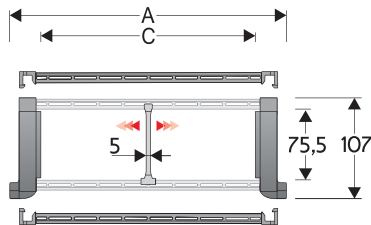

Separator

- Unassembled	Part.no S309S/3178
- Assembled	Part.no S309S/3178MCI for chain opening outer radius
- Assembled	Part.no S309S/3178MCE for chain opening inner radius

Pin

Part.no PG329

Technical characteristics

Speed	3 m/s
Acceleration	13 m/s ²

For higher requirements please consult our technical dept.

A	B	C	D	R	Weight/m	Chain
mm	mm	mm	mm	mm	kg	Part Number
148	107	84	75,5	200-250-300-350-400-500-600	5,70	329CD084 □□□ *
173	107	109	75,5	200-250-300-350-400-500-600	6,11	329CD109 □□□ *
180	107	116	75,5	200-250-300-350-400-500-600	6,24	329CD116 □□□ *
203	107	139	75,5	200-250-300-350-400-500-600	6,62	329CD139 □□□ *
243	107	179	75,5	200-250-300-350-400-500-600	7,33	329CD179 □□□ *
278	107	214	75,5	200-250-300-350-400-500-600	7,96	329CD214 □□□ *
304	107	240	75,5	200-250-300-350-400-500-600	8,40	329CD240 □□□ *
328	107	264	75,5	200-250-300-350-400-500-600	8,80	329CD264 □□□ *
354	107	290	75,5	200-250-300-350-400-500-600	9,26	329CD290 □□□ *
378	107	314	75,5	200-250-300-350-400-500-600	9,68	329CD314 □□□ *
404	107	340	75,5	200-250-300-350-400-500-600	10,12	329CD340 □□□ *
428	107	364	75,5	200-250-300-350-400-500-600	10,55	329CD364 □□□ *
483	107	419	75,5	200-250-300-350-400-500-600	11,73	329CD419 □□□ *
552	107	488	75,5	200-250-300-350-400-500-600	12,91	329CD488 □□□ *

*Complete the code by inserting the value of the radius (R): Ex. 329CD116 [2] [5] [0]

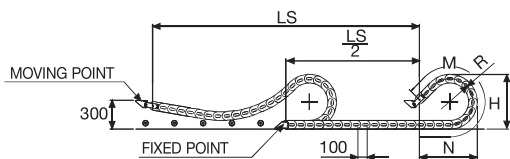

Length of chain (L)

Half travel distance ($\frac{LS}{2}$)

plus length of curve (M)

$$L = \frac{LS}{2} + M$$

R	H	N	M
mm	mm	mm	mm
200	506	595	1345
250	606	765	1780
300	706	940	2220
350	806	1110	2655
400	906	1280	3095
500	1106	1625	3970
600	1306	1965	4845



End Brackets

The end brackets set allows the two ends of the chain to be attached to the equipment. One set includes two pivoting end brackets to be installed at the moving point and two standard steel end brackets to be installed at the fixed point.

**Bright Zinc Plated Steel
Movable Type***
(moving point)**

**Bright Zinc Plated Steel
Type***
(fixed point)**

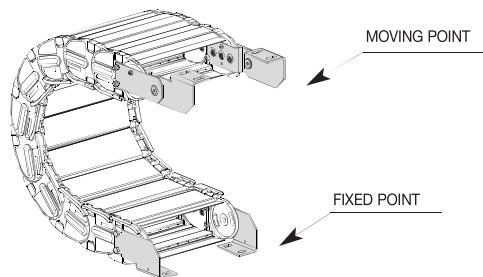
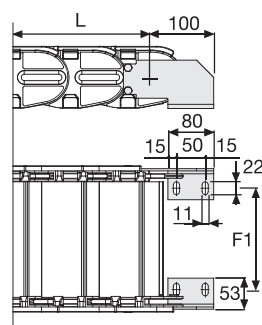
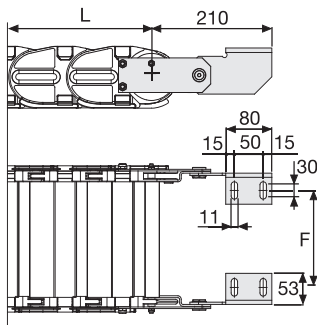

Fig. A
Chain fixed outside the radius. (Fig A)



Chain Type	F mm
329CD084	60
329CD109	85
329CD116	92
329CD139	115
329CD179	155
329CD214	190
329CD240	216
329CD264	240
329CD290	266
329CD314	290
329CD340	316
329CD364	340
329CD419	395
329CD488	464

Chain Type	F1 mm
329CD084	71
329CD109	96
329CD116	103
329CD139	126
329CD179	166
329CD214	201
329CD240	227
329CD264	251
329CD290	277
329CD314	301
329CD340	327
329CD364	351
329CD419	406
329CD488	475

Bright Zinc Plated Steel Type Part Numbers

Chain Type	End Brackets Set
329CD..	A329CD□□□*KM

Chain Type	End Brackets Set
329CD..	A329CD□□□*K

* Inner width (C)

*** Available on request in stainless steel

Serie Sliding

329CD Nylon Sliding Cable Chain with opening aluminium covers

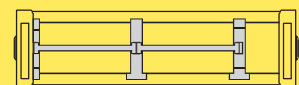

Separation System
To choose the separators see
page. 196

3

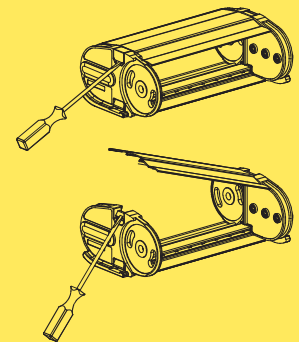

How to open the cover

For further information please
consult Brevetti Stendalto's
Technical Office

Serie Sliding

478MU

Nylon Cable Chain with opening frames

Inner height (D) 75,5 mm

Sideband & Frame construction with large anti-friction single-pin.

As standard the chain comes with frames every second link, on request with frames every link.

Modular separator systems are available

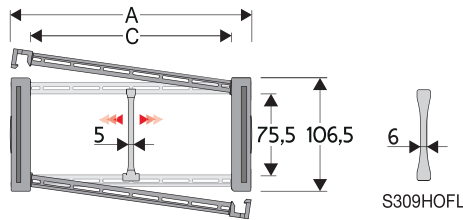

Separator

- Unassembled Part.no S309S/3178
- Assembled* Part.no S309S/3178MCI
- Assembled** Part.no S309S/3178MCE

Strong-hold separator

for C > 250 mm

- Unassembled Part.no S309HOFL

- Assembled Part.no S309HOFLMC

Pin

- Part.no PG475

* for chain opening outer radius
** for chain opening inner radius

Technical characteristics

Speed	3 m/s
Acceleration	8 m/s ²

For higher requirements please consult our technical dept.

A	B	C	D	R	Weight/m	Chain
mm	mm	mm	mm	mm	kg	Part number
112	106,5	74	75,5	180-200-250-300-350-400	3,70	478MU074 □□□ *
132	106,5	94	75,5	180-200-250-300-350-400	3,80	478MU094 □□□ *
157	106,5	119	75,5	180-200-250-300-350-400	3,85	478MU119 □□□ *
164	106,5	126	75,5	180-200-250-300-350-400	3,90	478MU126 □□□ *
187	106,5	149	75,5	180-200-250-300-350-400	3,95	478MU149 □□□ *
227	106,5	189	75,5	180-200-250-300-350-400	4,05	478MU189 □□□ *
262	106,5	224	75,5	180-200-250-300-350-400	4,15	478MU224 □□□ *
288	106,5	250	75,5	180-200-250-300-350-400	4,25	478MU250 □□□ *
312	106,5	274	75,5	180-200-250-300-350-400	4,30	478MU274 □□□ *
338	106,5	300	75,5	180-200-250-300-350-400	4,37	478MU300 □□□ *
362	106,5	324	75,5	180-200-250-300-350-400	4,45	478MU324 □□□ *
388	106,5	350	75,5	180-200-250-300-350-400	4,55	478MU350 □□□ *
412	106,5	374	75,5	180-200-250-300-350-400	4,60	478MU374 □□□ *
467	106,5	429	75,5	180-200-250-300-350-400	4,80	478MU429 □□□ *
536	106,5	498	75,5	180-200-250-300-350-400	5,00	478MU498 □□□ *

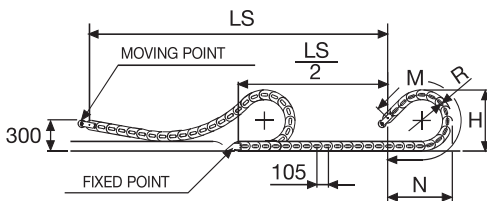

Length of chain (L)

Half travel distance ($\frac{LS}{2}$)

plus length of curve (M)

$$L = \frac{LS}{2} + M$$

R	H	N	M
mm	mm	mm	mm
180	466,5	495	1155
200	506,5	570	1330
250	606,5	745	1765
300	706,5	920	2205
350	806,5	1090	2640
400	906,5	1265	3080

*Complete the code by inserting the value of the radius (R): Ex. 478MU119 □ □ □ □

Chain equipped with nylon frame every pitch: complete the code by inserting the letter D. 478MU119150 □



Version with frames mounted on every pitch.

End Brackets

The end brackets set allows the two ends of the chain to be attached to the equipment. One set includes two pivoting end brackets to be installed at the moving point and two standard steel end brackets to be installed at the fixed point.

**Bright Zinc Plated Steel
Movable Type*****

**Bright Zinc Plated Steel
Type*** (moving point) (fixed point)**

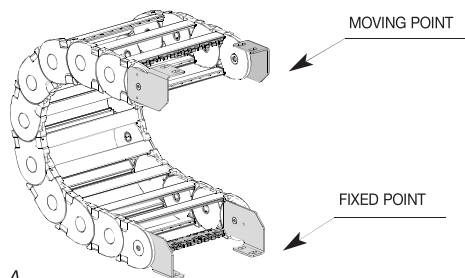
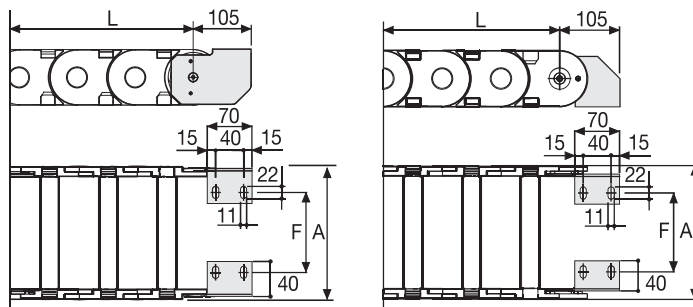

Fig. A
Chain fixed outside the radius. (Fig A)



Chain Type	F mm
478MU074	35
478MU094	55
478MU119	80
478MU126	87
478MU149	110
478MU189	150
478MU224	185
478MU250	211
478MU274	235
478MU300	261
478MU324	285
478MU350	311
478MU374	335
478MU467	390
478MU498	459

Bright Zinc Plated Steel Type Part Numbers

Complete Set Assembled	
Chain	End Brackets
Type	Set
478MU	A478M□□□*KM

Complete Set Unassembled	
Chain	End Brackets
Type	Set
478MU..	A478M□□□*K

Tiewrap Clamp	
	Part Number
Assembled	CFC478M□□□*KM
Unassembled	CFC478M□□□*K

* Inner width (C)

*** Available on request in stainless steel

Serie Sliding

478MU

Nylon Cable Chain
with opening frames

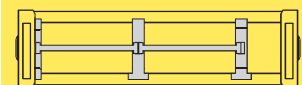

Separation System
To choose the separators see
page. 196

3

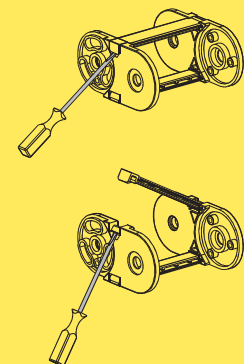

How to open the cover.

For further information please
consult Brevetti Stendalto's
Technical Office

Serie Sliding

478PU

Nylon Cable Chain with opening frames

Inner height (D) 75,5 mm

Sideband & Frame construction with large anti-friction single-pin. Covers are opening from inner radius or from outer radius. Vertical and horizontal modular separator system are available.

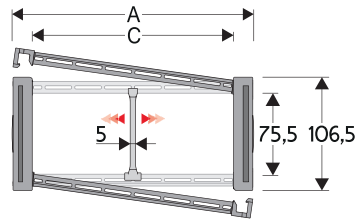

Separator

- Unassembled	Part.no S309S/3178
- Assembled*	Part.no S309S/3178MCI
- Assembled**	Part.no S309S/3178MCE

Pin

Part.no PG475

* for chain opening outer radius
** for chain opening inner radius

Technical characteristics

Speed	3 m/s
Acceleration	8 m/s ²

For higher requirements please consult our technical dept.

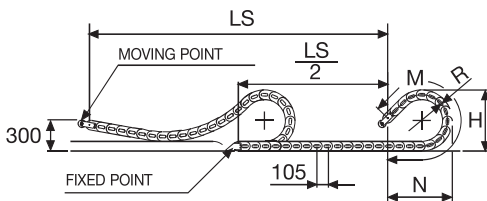

A	B	C	D	R	Weight/m	Chain
mm	mm	mm	mm	mm	kg	Part number
112	106,5	74	75,5	180-200-250-300-350-400	4,60	478PU074 □□□ *
132	106,5	94	75,5	180-200-250-300-350-400	4,80	478PU094 □□□ *
157	106,5	119	75,5	180-200-250-300-350-400	5,10	478PU119 □□□ *
164	106,5	126	75,5	180-200-250-300-350-400	5,15	478PU126 □□□ *
187	106,5	149	75,5	180-200-250-300-350-400	5,40	478PU149 □□□ *
227	106,5	189	75,5	180-200-250-300-350-400	5,80	478PU189 □□□ *
262	106,5	224	75,5	180-200-250-300-350-400	6,20	478PU224 □□□ *
288	106,5	250	75,5	180-200-250-300-350-400	6,50	478PU250 □□□ *
312	106,5	274	75,5	180-200-250-300-350-400	6,75	478PU274 □□□ *
338	106,5	300	75,5	180-200-250-300-350-400	7,05	478PU300 □□□ *
362	106,5	324	75,5	180-200-250-300-350-400	7,30	478PU324 □□□ *
388	106,5	350	75,5	180-200-250-300-350-400	7,55	478PU350 □□□ *
412	106,5	374	75,5	180-200-250-300-350-400	7,85	478PU374 □□□ *
467	106,5	429	75,5	180-200-250-300-350-400	8,50	478PU429 □□□ *
536	106,5	498	75,5	180-200-250-300-350-400	9,20	478PU498 □□□ *

*Complete the code by inserting the value of the radius (R): Ex. 478PU119 □□□ □□

Length of chain (L)

Half travel distance ($\frac{LS}{2}$)

plus length of curve (M)

$$L = \frac{LS}{2} + M$$

R	H	N	M
mm	mm	mm	mm
180	466,5	495	1155
200	506,5	570	1330
250	606,5	745	1765
300	706,5	920	2205
350	806,5	1090	2640
400	906,5	1265	3080



End Brackets

The end brackets set allows the two ends of the chain to be attached to the equipment. One set includes two pivoting end brackets to be installed at the moving point and two standard steel end brackets to be installed at the fixed point.

Bright Zinc Plated Steel Movable Type*** **Bright Zinc Plated Steel Type*** (moving point) (fixed point)**

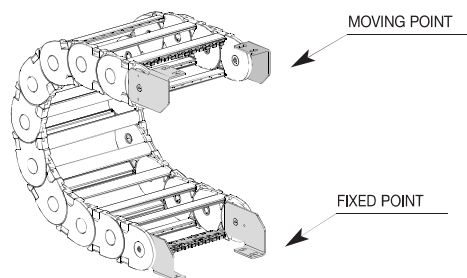
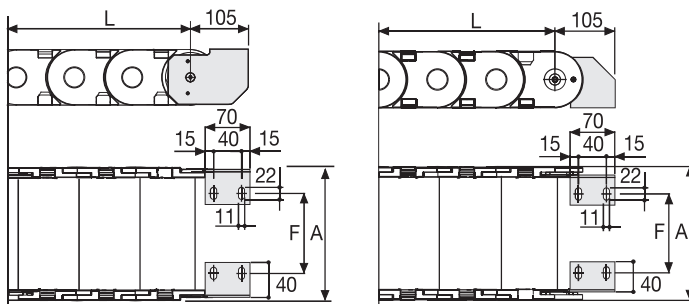

Fig. A
Chain fixed outside the radius. (Fig A)



Chain Type	F mm
478PU074	35
478PU094	55
478PU119	80
478PU126	87
478PU149	110
478PU189	150
478PU224	185
478PU250	211
478PU274	235
478PU300	261
478PU324	285
478PU350	311
478PU374	335
478PU429	390
478PU498	459

Bright Zinc Plated Steel Type Part Numbers

Complete Set Assembled	
Chain	End Brackets
Type	Set
478PU...	A478P□□□*KM

Complete Set Unassembled	
Chain	End Brackets
Type	Set
478PU...	A478P□□□*K

Tiewrap Clamp	
Part Number	
Assembled	CFC478M□□□*KM
Unassembled	CFC478M□□□*K

* Inner width (C)

*** Available on request in stainless steel

Serie Sliding

478PU

Nylon Cable Chain
with opening frames

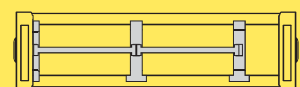

Separation System
To choose the separators see
page. 196

3

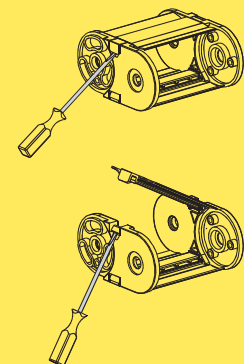

How to open the cover.

For further information please
consult Brevetti Stendalto's
Technical Office

Serie Sliding

60PU/R1

Nylon Cable Chain with opening frames

Inner height (D) 60,5 mm

Sideband & Frame construction with large anti-friction single-pin. Frames opening from inner and outer radius.

As standard the chain comes with frames every second link, on request with frames every link.

Vertical separators are available

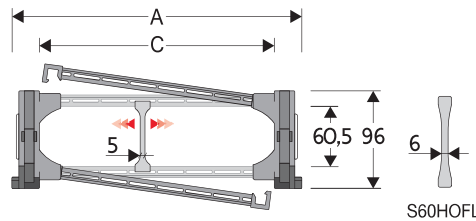

Separator

- Unassembled Part.no S60SMF
- Assembled Part.no S60SMFMC

Strong-hold separator

for C > 250 mm

- Unassembled Part.no S60HOFL
- Assembled Part.no S60HOFLMC

Pin

Part.no PNE60-PNI60

Technical characteristics

Speed	5 m/s
Acceleration	13 m/s ²

For higher requirements please consult our technical dept.

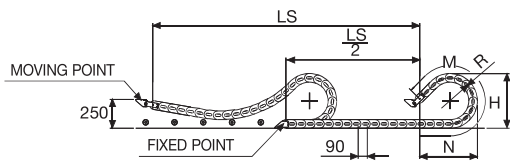

Length of chain (L)

Half travel distance ($\frac{LS}{2}$)

plus length of curve (M)

$$L = \frac{LS}{2} + M$$

R	H	N	M
mm	mm	mm	mm
200	490	715	1625
250	590	925	2130
300	690	1130	2635
400	890	1550	3645

A	B	C	D	R	Weight/m	Chain
mm	mm	mm	mm	mm	kg	Part number
169	96	115	60,5	200-250-300-400	5,37	60PU115 □□□ *
189	96	135	60,5	200-250-300-400	5,46	60PU135 □□□ *
214	96	160	60,5	200-250-300-400	5,52	60PU160 □□□ *
221	96	167	60,5	200-250-300-400	5,54	60PU167 □□□ *
244	96	190	60,5	200-250-300-400	5,61	60PU190 □□□ *
284	96	230	60,5	200-250-300-400	5,77	60PU230 □□□ *
319	96	265	60,5	200-250-300-400	5,91	60PU265 □□□ *
345	96	291	60,5	200-250-300-400	5,99	60PU291 □□□ *
369	96	315	60,5	200-250-300-400	6,07	60PU315 □□□ *
395	96	341	60,5	200-250-300-400	6,17	60PU341 □□□ *
419	96	365	60,5	200-250-300-400	6,26	60PU365 □□□ *
445	96	391	60,5	200-250-300-400	6,34	60PU391 □□□ *
469	96	415	60,5	200-250-300-400	6,43	60PU415 □□□ *
524	96	470	60,5	200-250-300-400	6,75	60PU470 □□□ *
593	96	539	60,5	200-250-300-400	7,08	60PU539 □□□ *

*Complete the code by inserting the value of the radius (R): Ex. 60PU115 [2] [5] [0]

Chain equipped with nylon frame every pitch: complete the code by inserting the letter D. 60PU115250 [D]



End Brackets

The end brackets set allows the two ends of the chain to be attached to the equipment. One set includes two pivoting end brackets to be installed at the moving point and two standard steel end brackets to be installed at the fixed point.

Bright Zinc Plated Steel Movable Type***

Bright Zinc Plated Steel Type* (moving point) (fixed point)**

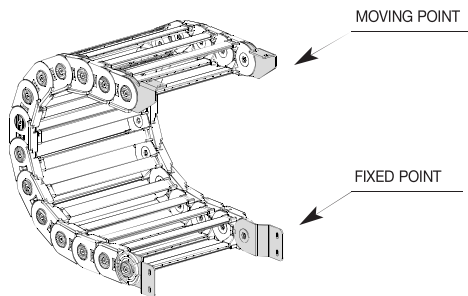
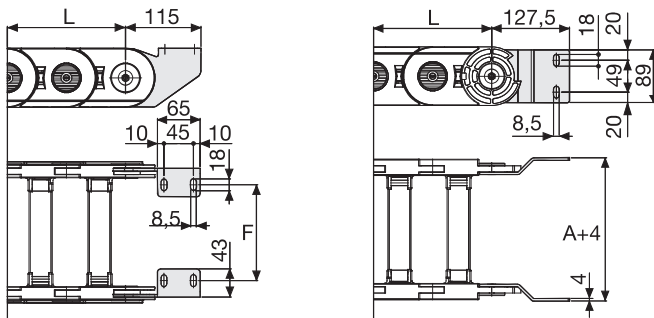

Fig. A
Chain fixed outside the radius. (Fig A)



Chain Type	F mm
60PU115	95
60PU135	115
60PU160	140
60PU167	147
60PU190	170
60PU230	210
60PU265	245
60PU291	271
60PU315	295
60PU341	321
60PU365	345
60PU391	371
60PU415	395
60PU470	450
60PU539	519

Bright Zinc Plated Steel Type Part Numbers

Complete Set Assembled Chain Type	End Brackets Set
60PU...	A60PKM□*

Complete Set Unassembled Chain Type	End Brackets Set
60PU...	A60PK

* 1=Pos.1; 2=Pos.2; 3=Pos.3

*** Available on request in stainless steel

Serie Sliding

60PU
Nylon Cable Chain
with opening frames

60R1
Nylon cables chain with
I-Roller system

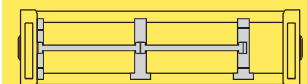

Separation System
To choose the separators
see page. 196

How to open the cover.

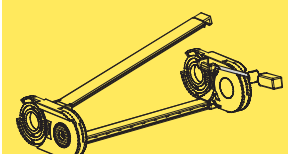
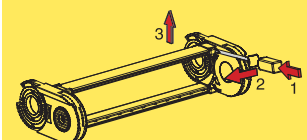

For further information please
consult Brevetti Stendalto's
Technical Office

Serie Sliding

80PU/R1

Nylon Cable Chain with opening frames

Inner height (D) 80,5 mm

Strong double share Sideband & Frame construction with large anti-friction single pin. The chain features screwed-on interchangeable sliding skids to offer durability even with high speed and loads. Frames opening from inner and outer radius. As standard the chain comes with frames every second link, on request with frames every link.

Separation systems are available.

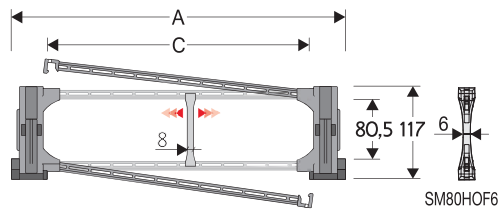

Separator

- Unassembled	Part.no S80F
- Assembled*	Part.no S80FMCI
- Assembled**	Part.no S80FMCE

Strong-hold separator

for C > 250 mm

- Unassembled	Part.no SM80HOF6L
- Assembled	Part.no SM80HOF6LMC

Pin

Sliding skid

Part.no PAT80

* for chain opening outer radius
** for chain opening inner radius

Technical characteristics

Speed	5 m/s
Acceleration	13 m/s ²

For higher requirements please consult our technical dept.

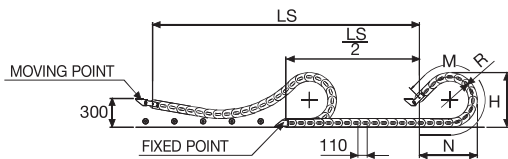

Length of chain (L)

Half travel distance ($\frac{LS}{2}$)

plus length of curve (M)

$$L = \frac{LS}{2} + M$$

R	H	N	M
mm	mm	mm	mm
200	510	695	1555
250	610	905	2060
300	710	1115	2565
400	910	1530	3575
500	1110	1945	4580
700	1510	2785	6600

A	B	C	D	R	Weight/m	Chain
mm	mm	mm	mm	mm	kg	Part number
195	117	115	80,5	200-250-300-400-500-700	8,60	80PU115 □□□ *
215	117	135	80,5	200-250-300-400-500-700	8,67	80PU135 □□□ *
240	117	160	80,5	200-250-300-400-500-700	8,73	80PU160 □□□ *
247	117	167	80,5	200-250-300-400-500-700	8,75	80PU167 □□□ *
270	117	190	80,5	200-250-300-400-500-700	8,80	80PU190 □□□ *
310	117	230	80,5	200-250-300-400-500-700	8,93	80PU230 □□□ *
345	117	265	80,5	200-250-300-400-500-700	9,05	80PU265 □□□ *
371	117	291	80,5	200-250-300-400-500-700	9,11	80PU291 □□□ *
395	117	315	80,5	200-250-300-400-500-700	9,17	80PU315 □□□ *
421	117	341	80,5	200-250-300-400-500-700	9,25	80PU341 □□□ *
445	117	365	80,5	200-250-300-400-500-700	9,33	80PU365 □□□ *
471	117	391	80,5	200-250-300-400-500-700	9,40	80PU391 □□□ *
495	117	415	80,5	200-250-300-400-500-700	9,47	80PU415 □□□ *
550	117	470	80,5	200-250-300-400-500-700	9,75	80PU470 □□□ *
619	117	539	80,5	200-250-300-400-500-700	10,00	80PU539 □□□ *

*Complete the code by inserting the value of the radius (R): Ex. 80PU115 □ □ □ *

Chain equipped with nylon frame every pitch: complete the code by inserting the letter D. 80PU115250 □



End Brackets

The end brackets set allows the two ends of the chain to be attached to the equipment. One set includes two pivoting end brackets to be installed at the moving point and two standard steel end brackets to be installed at the fixed point.

Bright Zinc Plated Steel Movable Type* (moving point)**

Bright Zinc Plated Steel Type* (fixed point)**

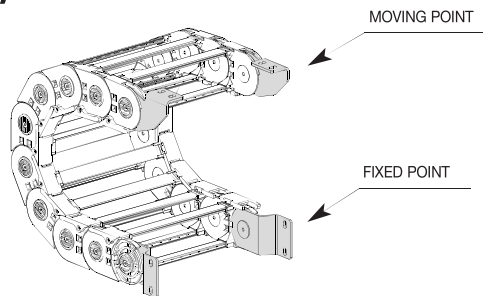
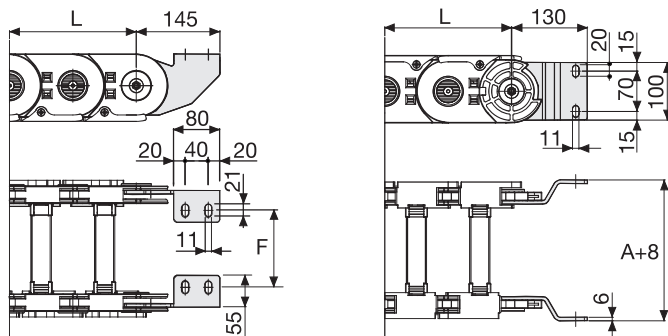

Fig. A
Chain fixed outside the radius. (Fig A)



Chain Type	F mm
80PU115	92
80PU135	112
80PU160	137
80PU167	144
80PU190	167
80PU230	207
80PU265	242
80PU291	268
80PU315	292
80PU341	318
80PU365	342
80PU391	368
80PU415	392
80PU470	447
80PU539	516

Bright Zinc Plated Steel Type Part Numbers

Complete Set Assembled	
Chain Type	End Brackets Set
80PU...	A80PKM□*

Complete Set Unassembled	
Chain Type	End Brackets Set
80PU...	A80PK

* 1=Pos.1; 2=Pos.2; 3=Pos.3

*** Available on request in stainless steel

Serie Sliding

80PU

Nylon Cable Chain with opening frames

Separation System
To choose the separators see page. 196

80R1

Nylon cables chain with I-Roller system



How to open the cover.

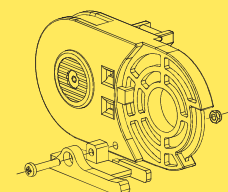
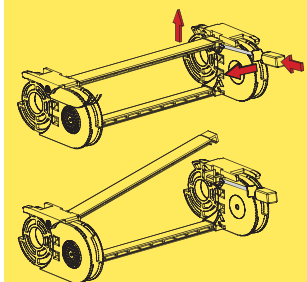

Sliding skid

For further information please consult Brevetti Stendalto's Technical Office

Serie Sliding

Guide Channel

445-660A-770A-326-328-20P-30P-60-H45-H57

Special guide channel allows the use of the chain for long travel distance.
Available in galvanised steel and, on request, in stainless steel.

Single Chain Application

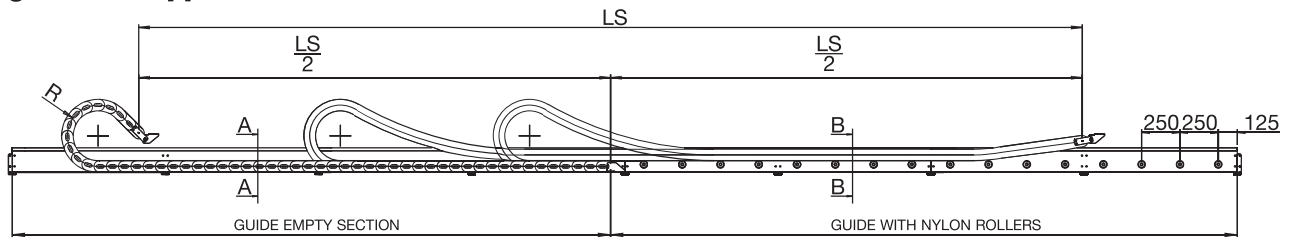

Double Chain Application

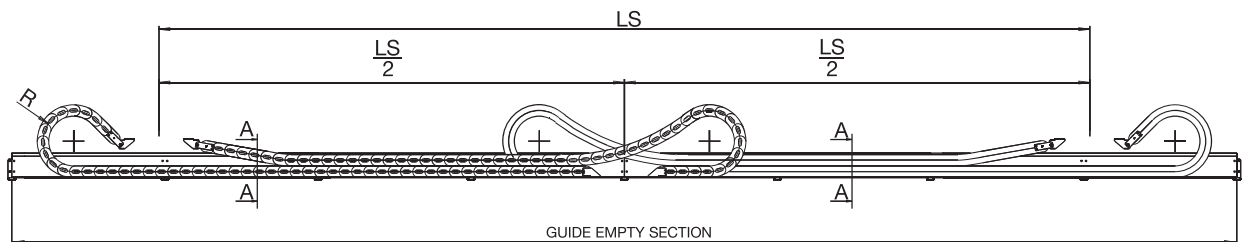

Channel guide is available in assembling kit composed by:
side walls 2 m standard length
joining and support plates
fixing screws
base
sliding device (nylon wheel/steel or plastic plate)

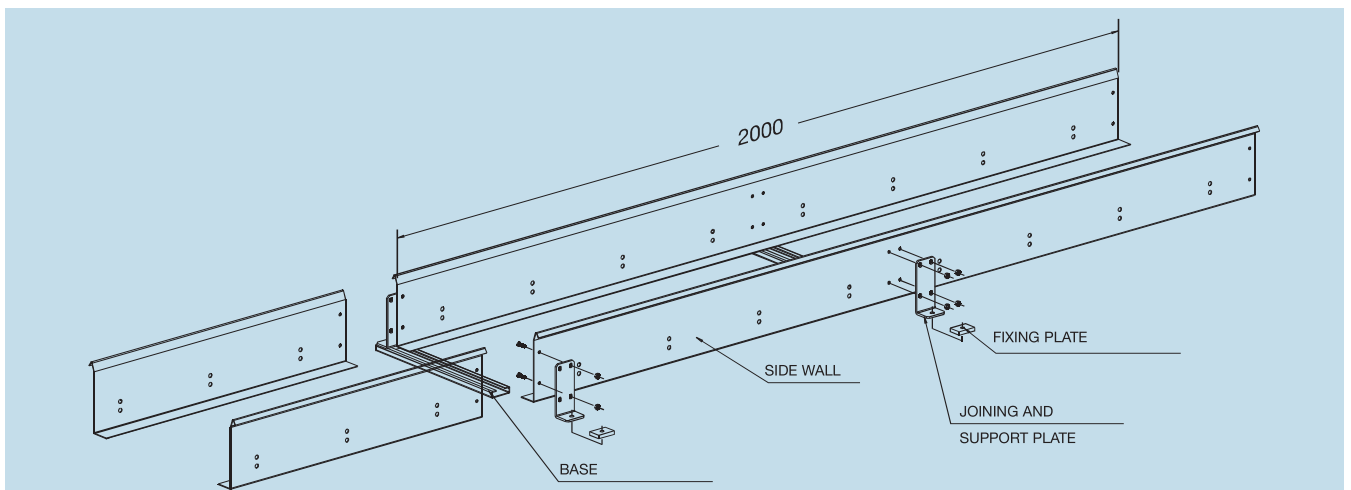

Empty Guide Section

Section A-A

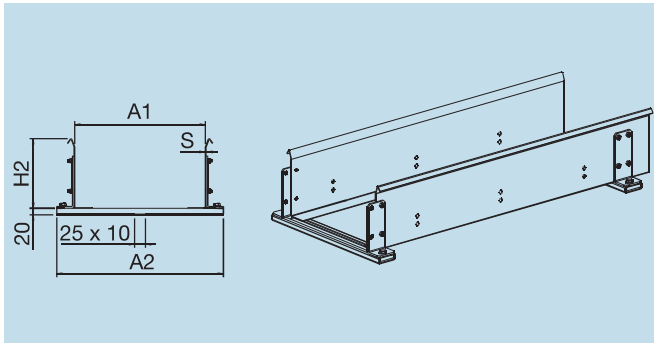

Part Number

CS326...

How to order

Chain part number **326B100150**

Guide channel part number **CS326B100**

Serie Sliding

Chain	H2 mm	H1 mm
445	160	64
660A	160	59
326	160	59
770A	160	79
328	160	79
60	190	96
H57	190	96
20P	160	59
30P	190	81,5
H45	160	79

Guide with Nylon Rollers

Section B-B

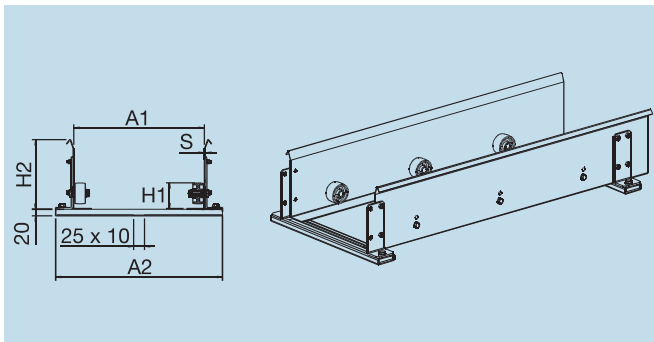

Part Number

CR326...

How to order

Chain part number **326B100150**

Guide channel part number **CR326B100**

Chain	S mm	A1 mm	A2 mm
445	1,5	A+4	A+87
H45	1,5	A+4	A+87
H57	1,5	A+4	A+87
660A	1,5	A+4	A+87
326	1,5	A+4	A+87
770A	1,5	A+4	A+87
328	1,5	A+4	A+87
60	1,5	A+4	A+87
20P	1,5	A+4	A+87
30P	2	A+4	A+88

Guide with Steel Sliding Plate

Section B-B

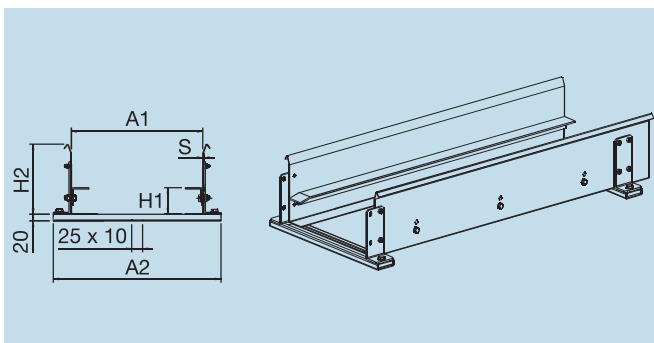

Part Number

CA326...

How to order

Chain part number **326B100150**

Guide channel part number **CA326B100**

Guide with Plastic Sliding Plate

Section B-B

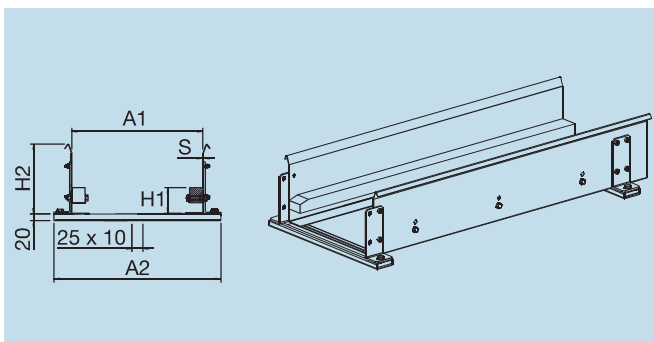

Part Number

CP326...

How to order

Chain part number **326B100150**

Guide channel part number **CP326B100**

For further information please consult Brevetti Stendalto's Technical Office

Serie Sliding

Guide Channel

478-319-329-80-35P-35PC-40P-H80-H110

Special guide channel allows the use of the chain for long travel distance
Available in galvanised steel and, on request, in stainless steel.

Single Chain Application

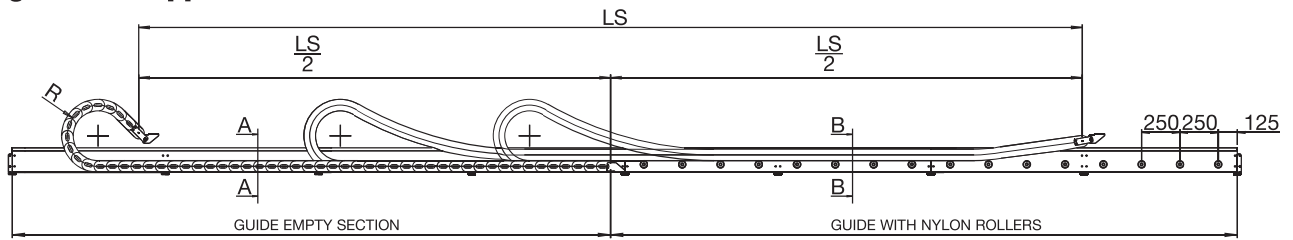

Double Chain Application

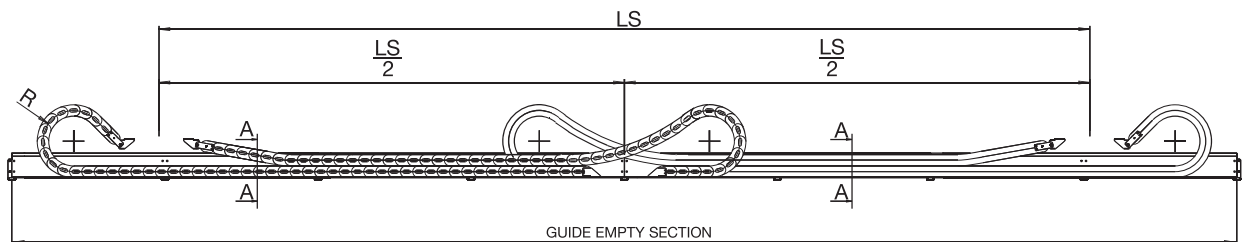

Channel guide is available in assembling kit composed by:
side walls 2 m standard length
joining and support plates
fixing screws
base
sliding device (nylon wheel/steel or plastic plate)

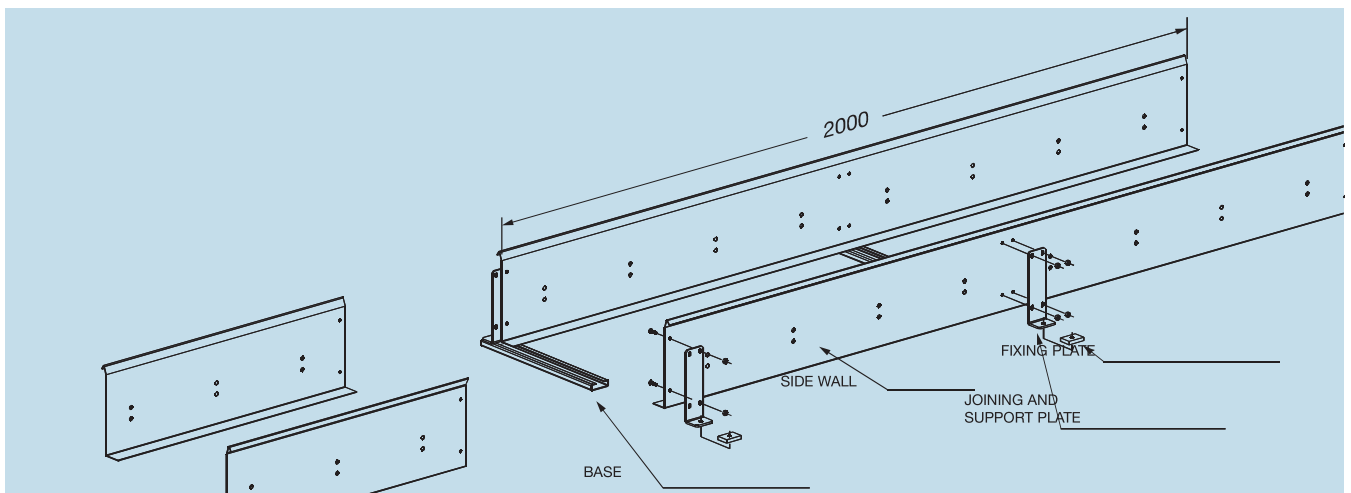

Empty Guide Section

Section A-A

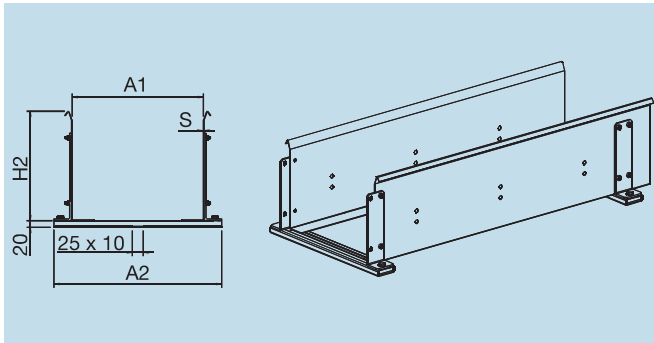

Part Number

CS319...

How to order

Chain part number **319B100200**

Guide channel part number **CS319B100**

Serie Sliding

Chain	H2 mm	H1 mm
319	250	107
329	250	107
80	250	117
35P	250	107
35CP	250	107
40	325	161,5
478	250	107
H80	250	117
H110	324	155

Guide with Nylon Rollers

Section B-B

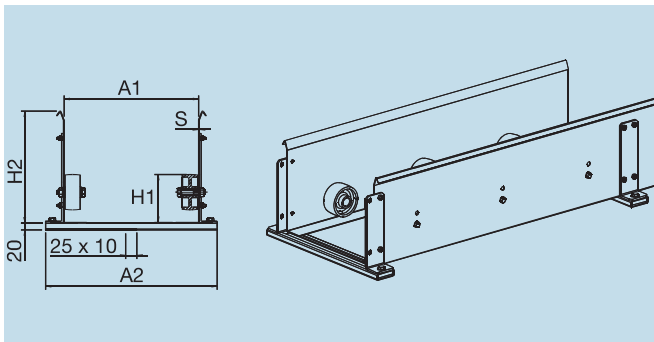

Part Number

CR319...

How to order

Chain part number **319B100200**

Guide channel part number **CR319B100**

Chain	S mm	A1 mm	A2 mm
319	1,5	A+8	A+91
329	1,5	A+8	A+91
80	2	A+8	A+92
35P	2	A+8	A+92
35CP	2	A+8	A+92
40	3	A+8	A+94
478	1,5	A+8	A+91
H80	2	A+8	A+92
H110	2,5	A+8	A+93

3

Guide with Steel Sliding Plate

Section B-B

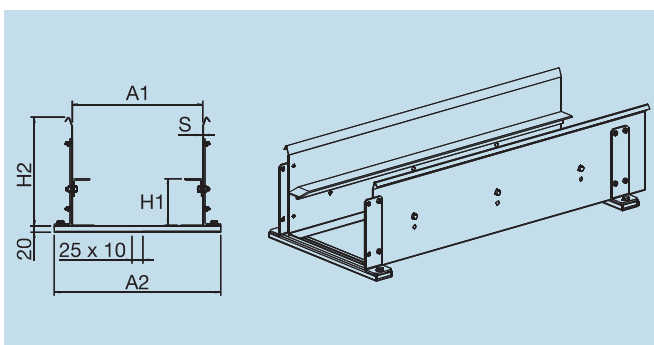

Part Number

CA319...

How to order

Chain part number **319B100200**

Guide channel part number **CA319B100**

Guide with Plastic Sliding Plate

Section B-B

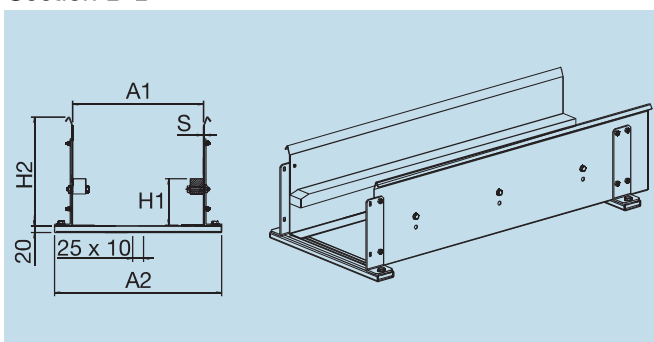

Part Number

CP319...

How to order

Chain part number **319B100200**

Guide channel part number **CP319B100**

For further information please consult Brevetti Stendalto's Technical Office

Serie Sliding

Aluminium Guide Channel 326-328-60-H57

Special aluminium guide channel allows the use of the chain for long travel distance.

Single Chain Application

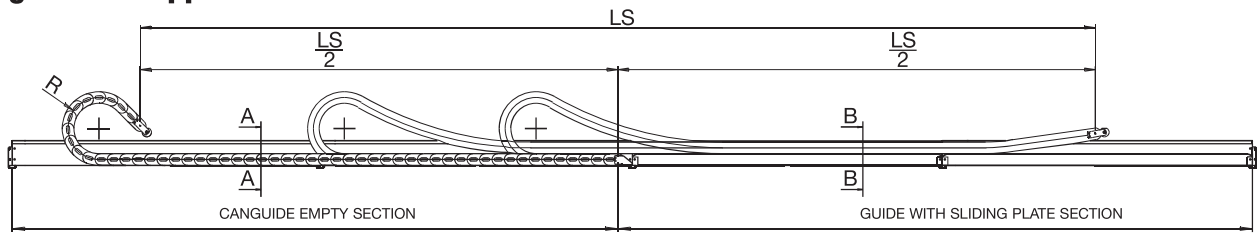

Double Chain Application

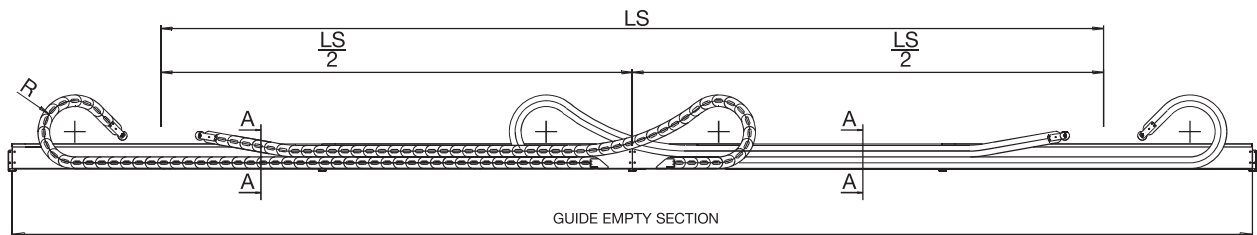

Channel guide is available in kit composed by:

- side walls 2 m standard length
- joining and fixing plates
- fixing screws
- base profile
- supporting parts (nylon wheels or plastic support plate)

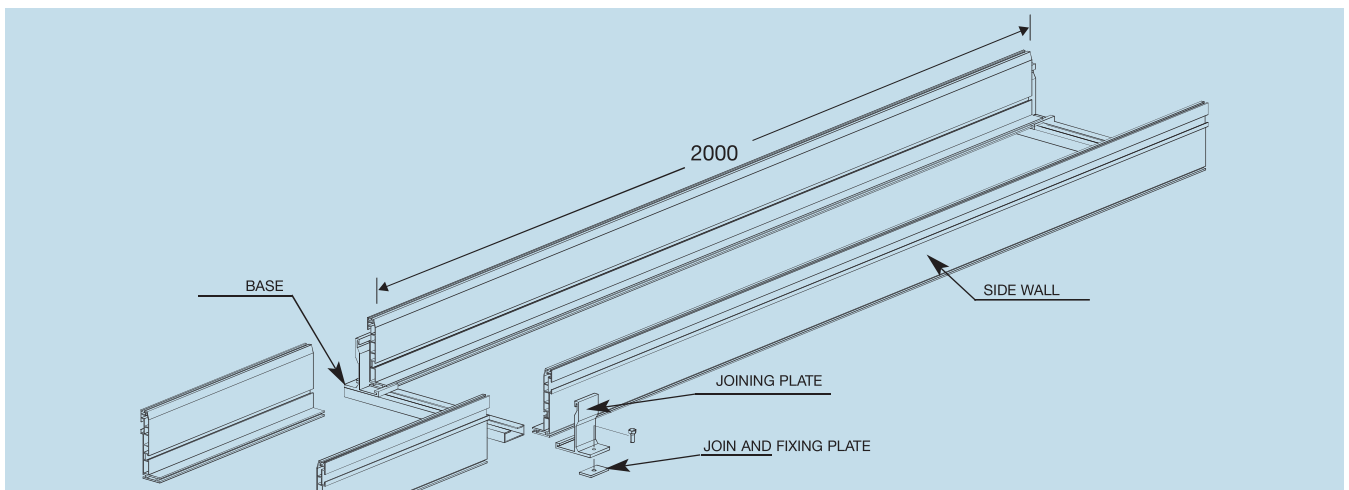

Empty Guide Section

Section A-A

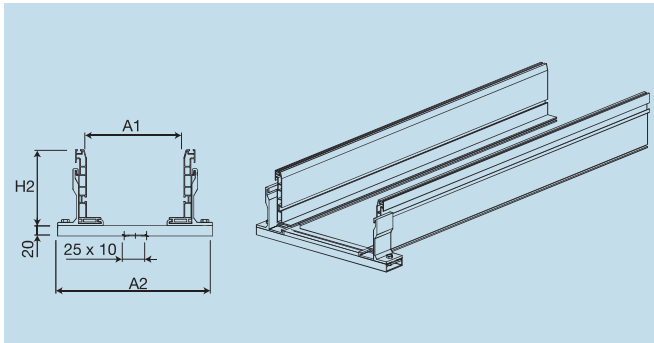

Guide with Nylon Rollers

Section B-B

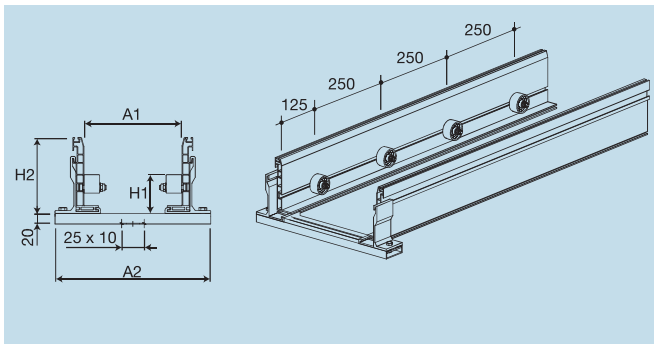

Guide with Plastic Sliding Plate

Section B-B

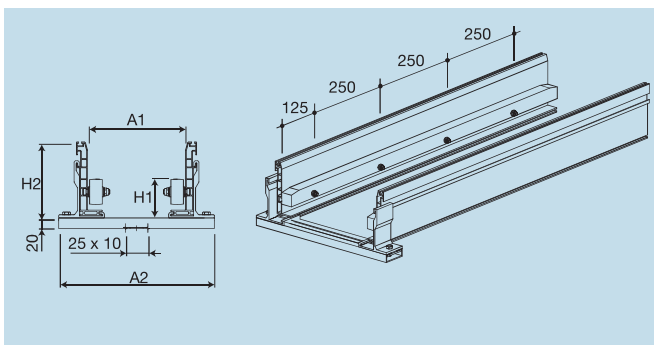

Part Number

CSA326...

How to order

Chain part number **326B100150**

Guide channel part number **CSA326B100**

CSA60...

Chain part number **60PI391250**

Guide channel part number **CSA60-391**

Serie Sliding

Chain	H2 mm	H1 mm
326	145	59
328	200	79
60	200	96
H57	200	96

Chain	A1 mm	A2 mm
326	A+4	A+114
328	A+4	A+114
60	A+4	A+114
H57	A+4	A+114

Part Number

CRA326...

How to order

Chain part number **326B100150**

Guide channel part number **CRA326B100**

CRA60...

Chain part number **60PI391250**

Guide channel part number **CRA60-391**

Part Number

CPA326...

How to order

Chain part number **326B100150**

Guide channel part number **CPA326B100**

CPA60...

Chain part number **60PI391250**

Guide channel part number **CPA60-391**